

### Function Block

Area Function Block

ID

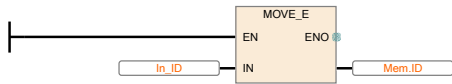

Inputs

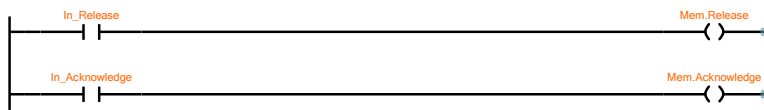

Operation Mode

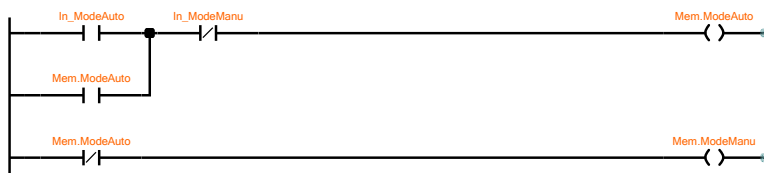

Try to reset fault and warning collector

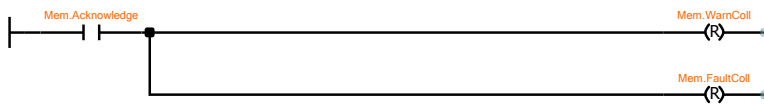

Outputs

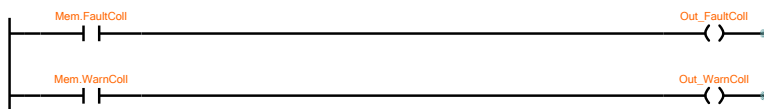



Function Block

Create Release Puls

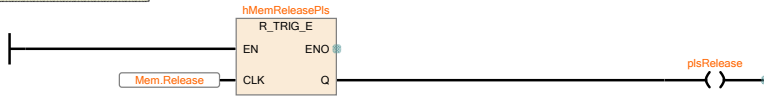

Status Open

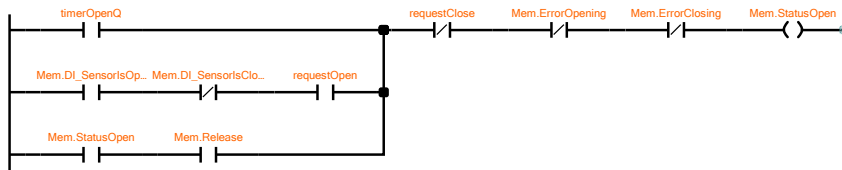

Status Closed

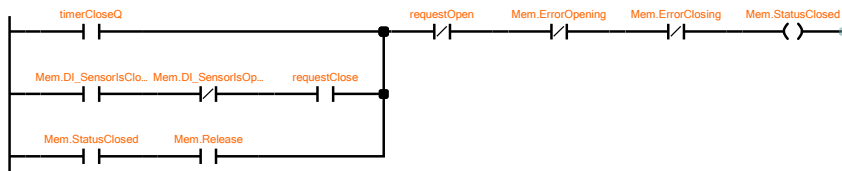

Prepaire Requests

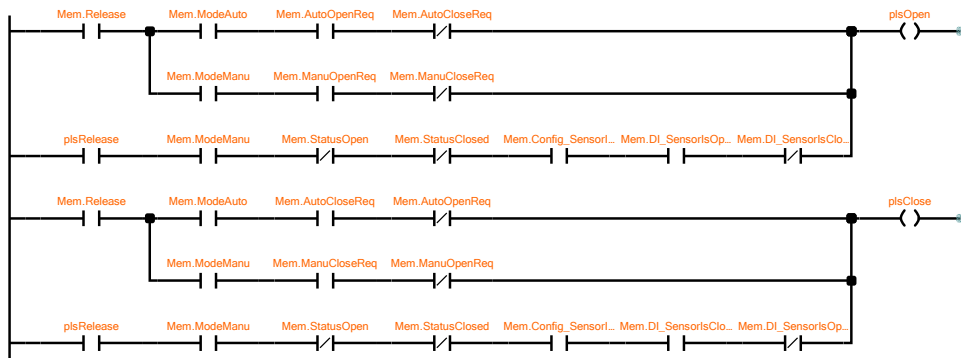

Request for state changes

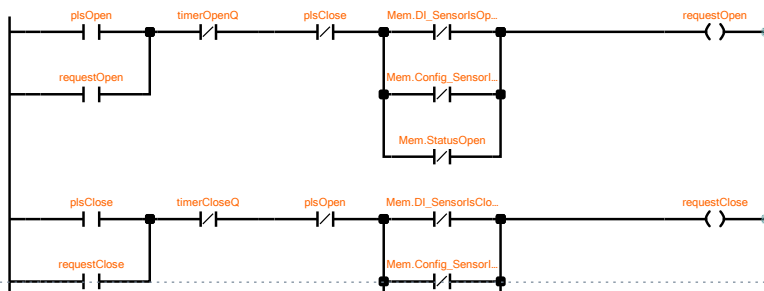

Function Block

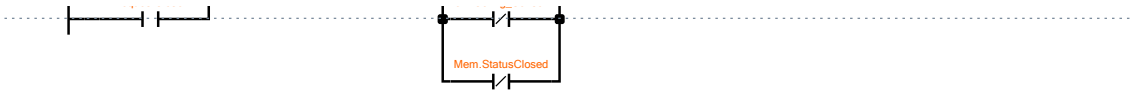

Timer Opening

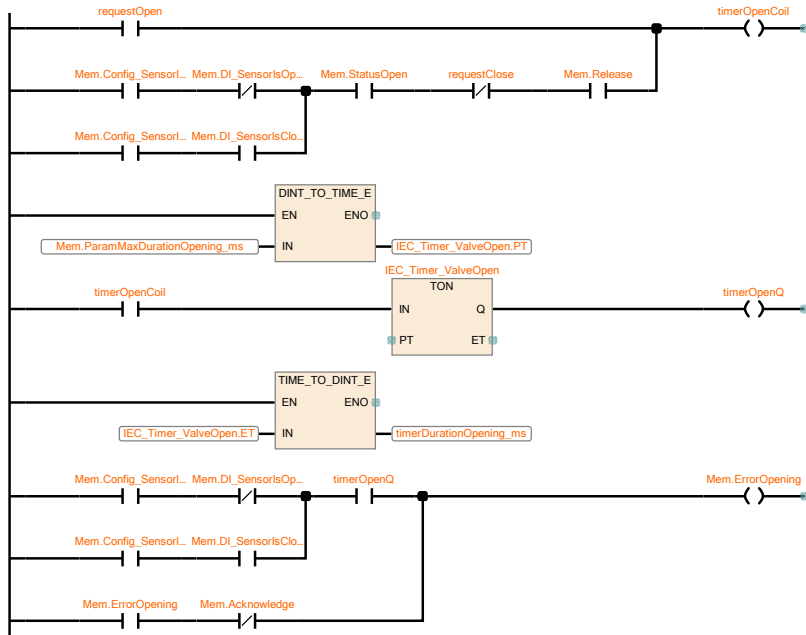

Timer Closing

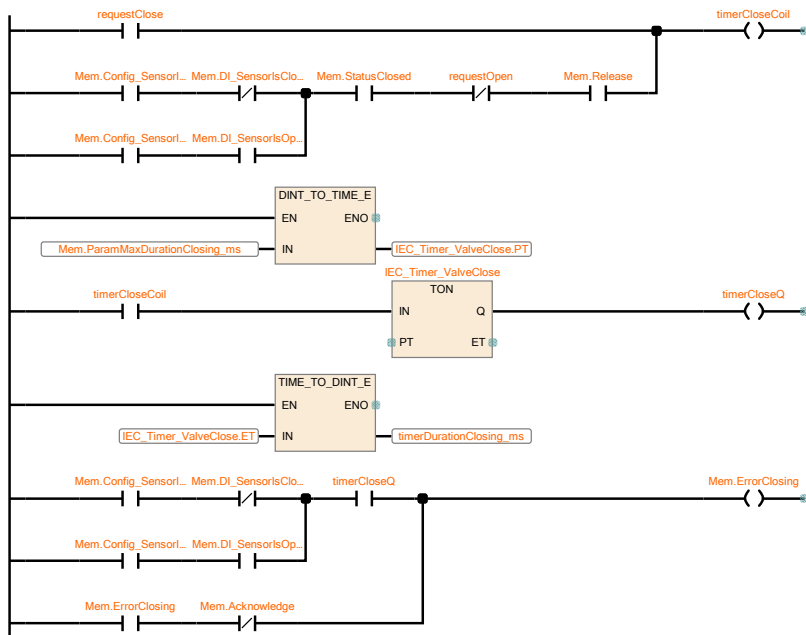

### Function Block

